

CTE SERIES

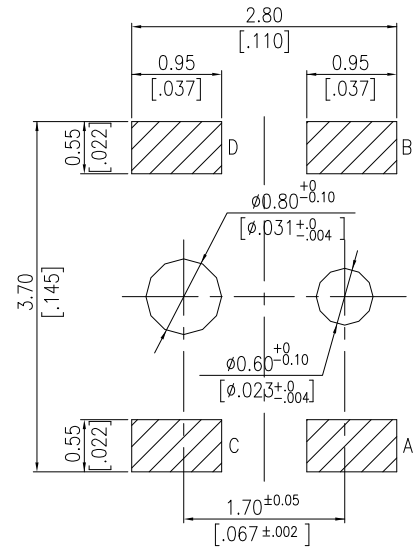

DIMENSIONS

CTE-P

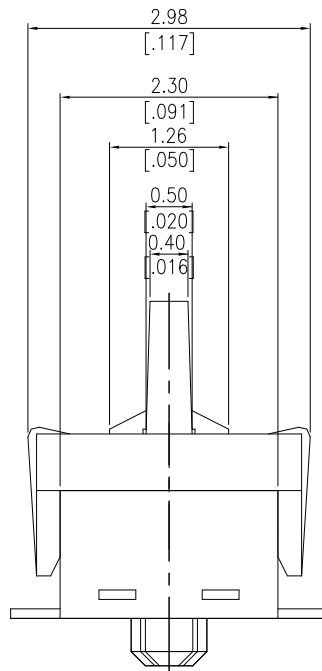
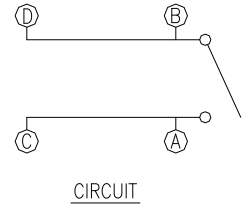
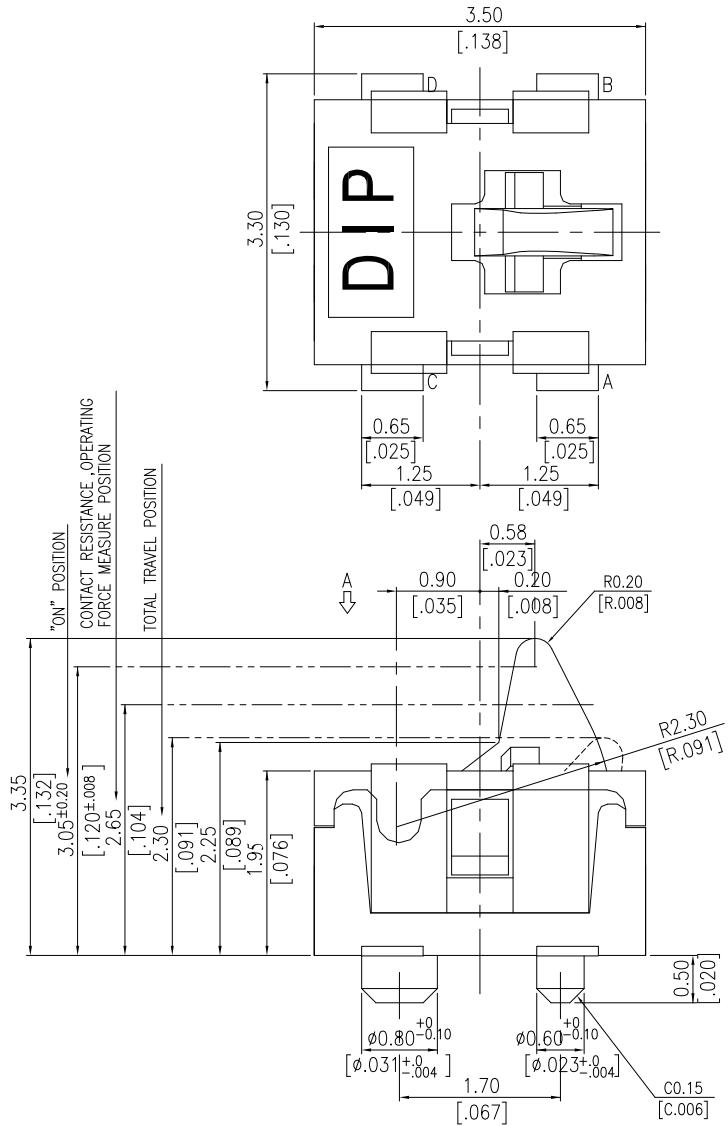

General Tolerance : $\pm 0.2\text{mm}$

CTE

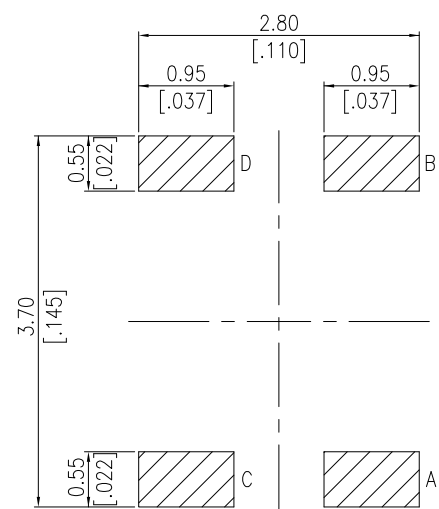
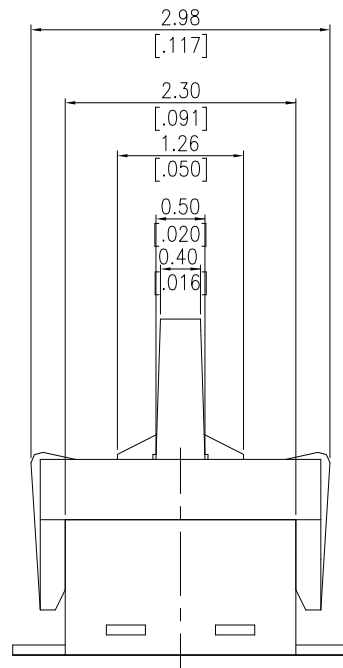
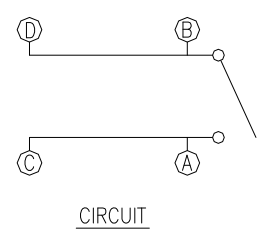
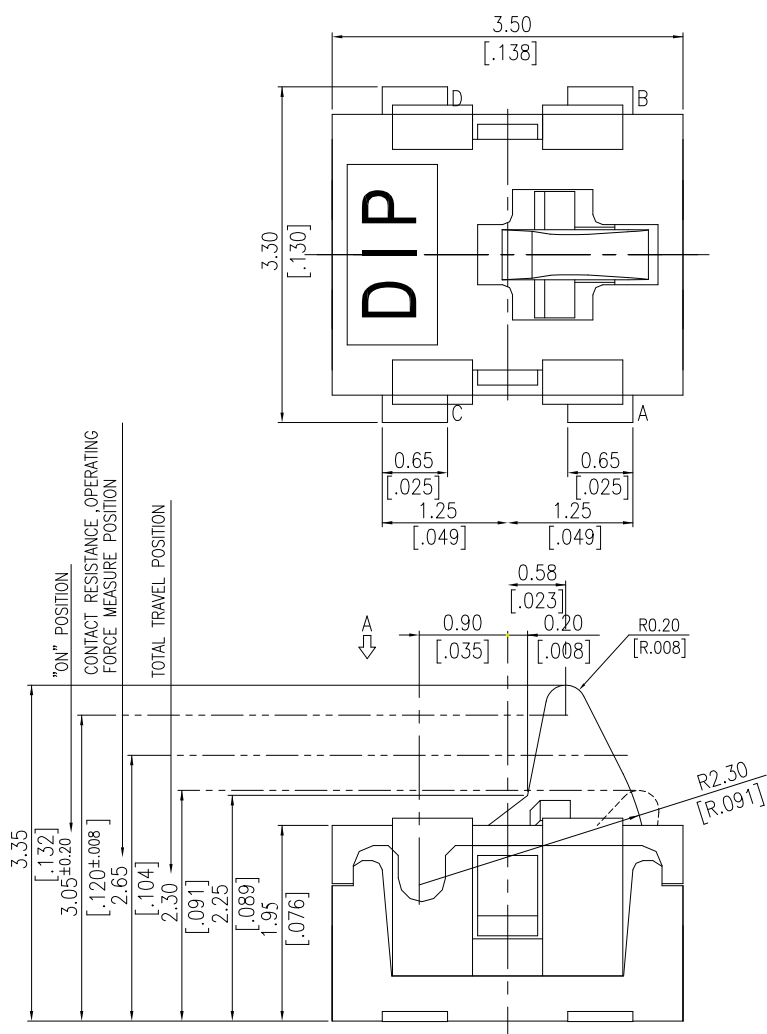

General Tolerance : $\pm 0.2\text{mm}$

HOW TO ORDER

C T E - □ - □ - □

Package :
T/R = Tape & Reel

Soldering :
V = Lead Free Solderable

Q = Halogen Free

Alignment Pin :

□ = Without Post

P = With Post

Detector Switch

SPECIFICATION

△MECHANICAL

Operation Force: 35gf max.

Stroke: 1.05 mm

Operation Temperature: -15°C to +70°C

Storage Temperature Range: -40°C to +85°C

△ELECTRICAL

Electrical Life : 100,000 cycles

Rating : 0.1mA~100mA, 20mA~5V DC

Contact Resistance : 500mΩ max.

Insulation Resistance : 100MΩ min. at 100VDC

Dielectric Strength : 250 VAC/ 1 minute

Contact Arrangement : 1 pole 1 throw.

MATERIAL

△BASE : UL 94V-0 High-Temp Thermoplastic

COLOR : Black

△COVER : UL 94V-0 High-Temp Thermoplastic

COLOR : Black

△STEM : UL 94V-0 High-Temp Thermoplastic

COLOR : Black

△CONTACT DISC : Stainless with silver plated.

△TERMINAL : PHOSPHOR BRONZE with silver plated.

SOLDERING PROCESSES

For best results, please follow these recommendations : Δ Reflow Temperature Profile:

Δ HAND SOLDERING : Use a soldering iron of 30 watts, Controlled at 608°F(320°C) approximately 2 seconds while applying.

Δ WAVE SOLDERING : Recommended solder temperature at 500°F(260°C) max. 5 seconds for through hole type.

Δ RELOW SOLDERING : When applying reflow soldering, The peak temperature or the reflow oven should be set to 260°C max.

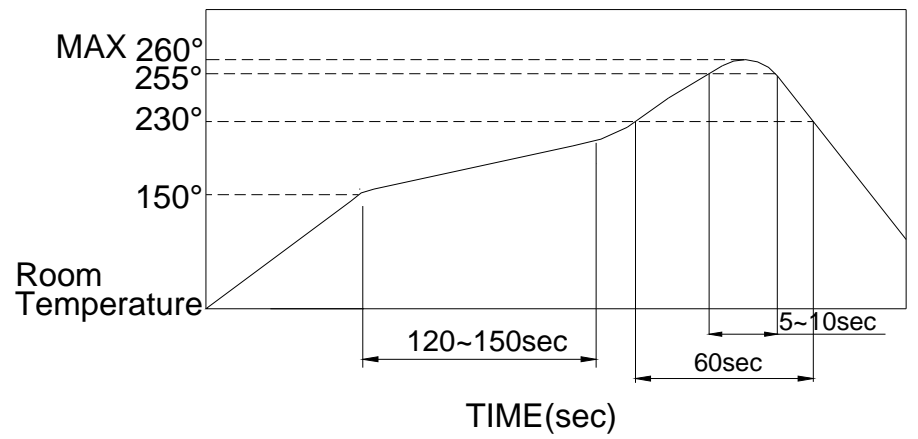

PACKING

CTE-P REEL

Part Number	Number Per Tube	Number Per Reel
CTE	--	1800
CTE-P	--	

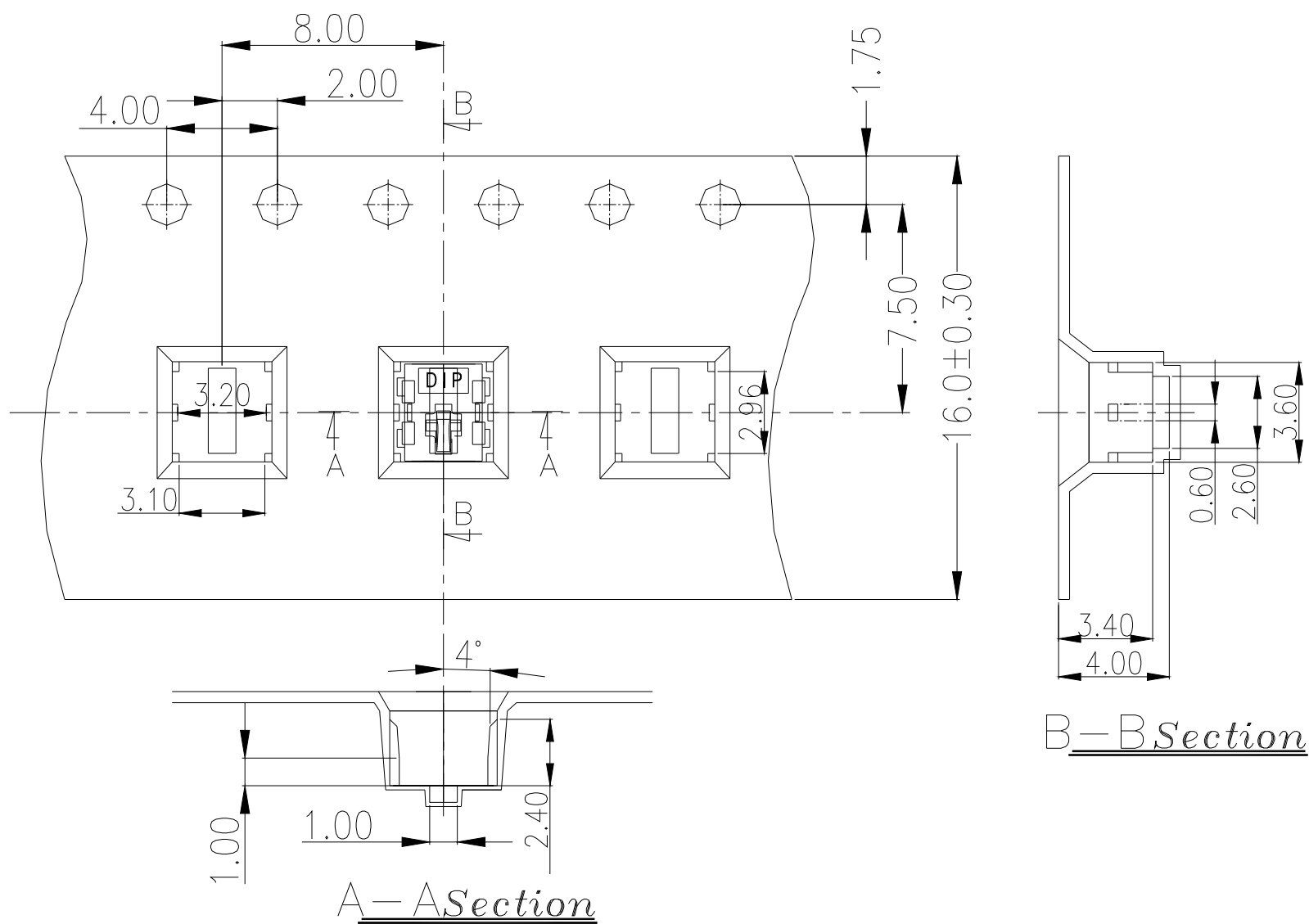

B-B Section

A-A Section

General Tolerance : $\pm 0.1\text{mm}$